

# **COLD AIR SYSTEM**

Installation Instructions for:  
Part Number 21-492  
1999.5 - 2005 Volkswagen Golf/GTI 2.0L 4 Cyl.  
1999.5 – 2005 Volkswagen Jetta 2.0L 4 Cyl.

**ADVANCED ENGINE MANAGEMENT INC.**

2205 126<sup>TH</sup> Street, Unit A Hawthorne, CA. 90250

Phone: (310) 484-2322 Fax: (310) 484-0152

[www.aempower.com](http://www.aempower.com)

Instruction Part Number: 10-338

The applications listed are covered by at least one of the following EO numbers:

1999.5 - 2003 Volkswagen Golf 2.0L 4 Cyl. C.A.R.B. E.O. #D-392-21

2004-2005 Volkswagen Golf 2.0L 4Cyl. C.A.R.B. E.O. #D-392-29

1999.5 – 2003 Volkswagen Jetta 2.0L 4 Cyl. C.A.R.B. E.O. #D-392-21

2005 Volkswagen Jetta 2.0L 4 Cyl. C.A.R.B. E.O. #D-392-29

Excludes 2003 MY LEV II SULEV 3VWXV02.0227

© Copyright 2006

Congratulations! You have just purchased the finest Air Induction & Filtration system for your car at any price!

The **AEM** Cold Air System is the result of extensive development on a wide variety of cars. Each system is engineered for the particular application. The **AEM** Cold Air System differs from all others in several ways. We take the inlet air from outside of the engine compartment where the inlet air is considerably cooler than the hot underhood air. The cooler inlet air temperature translates to more power during the combustion process because cool air is denser than warm air. **AEM** has conducted extensive inlet air temperature studies and we have seen temperature reductions of up to 50 degrees by pulling air from outside of the engine compartment. The air mass flow to the engine is increased because of the increased airflow *and* reduced inlet temperature, which translates to more power. The **AEM** Cold Air Systems are **50 states Street Legal** (some models and years still pending) and come with complete instructions for ease of installation.

Our system is constructed of lightweight aluminum and then painted with a zirconia based powder coat for superior heat insulating characteristics. The aluminum will not crack in extended use like plastic and it is actually lighter than plastic. The tube diameter and length are matched for each engine to give power over a broad rpm range. Unlike the plastic systems that use a continually diverging cross section, we take advantage of the acoustical energy in the duct to promote cylinder filling during the intake valve-opening event.

Our Dyno testing as well as **independent dyno tests** (see 7/97 Sport Compact Car Magazine) prove that the **AEM** Cold Air System produces as much as twice the power gain than any other system on the market.

## Bill of Materials for:

### Part Number 21-492

<u>QTY</u>	<u>PART #</u>	<u>DESCRIPTION</u>
1	2-498	Inlet Pipe
1	21-202	2.75" Air Filter & Clamp
3	444.460.04	6mm Nut
4	559999	6mm x 25mm x 1mm Washer
1	1228599	Soft Mount
1	5-275	2.75" Silicone Hose
1	2-649	Vacuum Hose Adapter
2	103-BLO-4420	2.75" Hose Clamp
18"	65004	5/8" Vacuum Hose
2	99034.032	1" Hose Clamps
1	10-338	Instructions
1	10-905	Warning Decal
2	10-922S	<b>AEM</b> Silver Decal

Read and understand these instructions **BEFORE** attempting to install this product.

### 1) Getting Started

- a) Make sure vehicle is parked on a level surface.
- b) Set parking brake.
- c) Jack the front of the vehicle and support with properly rated jack stands.
- d) Lift the plastic battery cover and disconnect both battery terminals. Remove the short positive lead from the positive battery terminal. **(Fig. 1)**
- e) If engine has run within the past two hours let it cool down.

### 2) Removing the stock air inlet system

- a) Swing the fuse box on top of the battery upwards and remove the hinge from the plastic battery box.
- b) Remove the four screws along the top of the radiator support. **(Fig. 2)** Remove the two plastic covers.
- c) Remove the battery hold down bolt and remove the battery from the vehicle. **(Fig. 3)**
- d) Remove the three bolts that secure the plastic battery box in place. Two bolts are located at the rear of the battery, on either side of the plastic wire tunnel. The third bolt is located on the radiator side of the battery. **(Fig. 4)**
- e) Unlatch the plastic wire tunnel cover on the backside of the battery box. **(Fig. 5)** Swing the cover open and remove the wire harness for the plastic battery box.
- f) Remove the plastic battery tray from the vehicle by removing the four bolts that secure it. **(Fig. 6)**
- g) Unplug the wire connector from the MAF sensor. **(Fig. 7)**
- h) Loosen the spring hose clamp that secures the inlet tube to the MAF sensor. Pull the inlet tube clear of the MAF sensor. **(Fig. 8)**
- i) Remove the breather hose from the air box by squeezing the plastic tabs to release the fitting. Use care to avoid damaging the o-ring. **(Fig. 9)**
- j) Remove the nut that secures the lower intake tube to the inner fender well. **(Fig. 10)**
- k) Remove the two bolts that secure the air box. **(Fig. 11)** Remove the air box, MAF sensor, and lower inlet tube from the vehicle.
- l) Remove the two screws securing the MAF sensor to the air box and set the MAF sensor aside in a safe place where it won't be damaged.
- m) Remove the screws securing the driver's side fender liner in place. Fold the fender liner back and out of the way to allow access to the area behind the front bumper.
- n) Remove the plastic cover behind the driver's side headlight. The cover is secured with three plastic rivets. The rivets are released by pushing the center of the plastic rivet with a small, pointed object. Two rivets are located at the top of the plastic cover, in the radiator support. **(Fig. 12)** The third rivet is accessible from under the car. **(Fig. 13)** Pull the plastic cover out of the engine bay. **(Fig. 14)**
- o) Remove the ground cable from the plastic clip in the fender well. **(Fig. 15)**

### 3) Installing the AEM Cold Air System

- a) When installing the **AEM** intake, DO NOT completely tighten the hose clamps, MAF sensor assembly or the mounting tab hardware until instructed to do so later in these instructions.
- b) Install the rubber mount in the **outermost** (towards driver's side of vehicle) hole to the rear of the large opening behind the headlight. Insert the rubber mount from below **(Fig. 16)** and secure it with a large fender washer and lock nut from the top. **(Fig. 17)**
- c) Place a large fender washer on the stud that originally secured the lower intake tube in place. **(Fig. 18)**
- d) Re-install the MAF sensor into the plastic intake hose, rotating the electrical connector to the original position. Use the original spring hose clamp. **Note: it is possible to install the MAF sensor backwards. DO NOT INSTALL BACKWARDS.** Make sure that the end with the flange (originally in the airbox) is still facing **away** from the throttle body. If you are still unsure, there is an arrow with the word "flow" molded into the MAF sensor body. **(Fig. 19)**
- e) Install the silicone hose onto the upper end of the **AEM** inlet pipe with one of the 2.75" hose clamps. The upper end is the end with the **AEM** decal. Loosely install the second 2.75" hose clamp onto the silicone hose.
- f) Feed the **AEM** inlet pipe into the engine bay and fender well. The lower bracket should line up with the rubber mount installed in step 3b. The upper mount should line up with the stud originally used to mount the lower intake tube.
- g) Install a large fender washer and lock nut onto both the rubber mount and the stud. **(Fig. 20 & 21)** Refer to the following diagram for proper rubber mount installation.

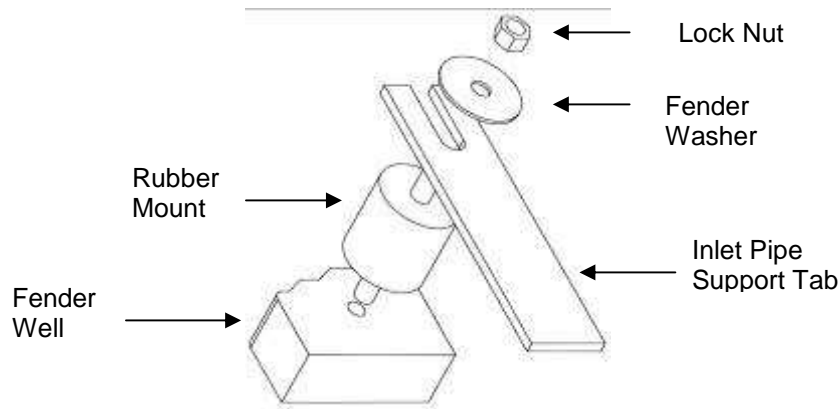

- h) Insert the MAF sensor into the into the silicone hose on the **AEM** inlet pipe. Make sure the MAF sensor is still rotated correctly in the factory position. Plug in the MAF sensor wire connector.
  - i) Install the **AEM** air filter onto the bottom of the **AEM** inlet pipe using the supplied hose clamp. Make sure the filter does not contact the horn or the plastic fender liner. **(Fig. 22)**
  - j) Adjust the inlet system for best fitment and snug the hose clamps and locknuts down. **(Make sure that no part of the inlet system comes into contact with any part of the vehicle.)**
  - k) Connect the factory breather hose to the **AEM** vacuum hose adapter. Line the clips on the plastic hose up with the flats machined into the adapter. **(Fig. 23)** It may be helpful to lubricate the o-ring with a small amount of clean engine oil. Use caution to avoid damaging the o-ring.
  - l) Install the supplied 5/8" vacuum hose section from the **AEM** adapter to the nipple on the back of the **AEM** inlet pipe with the two supplied 1" hose clamps. Route the hose in a broad arc under the **AEM** inlet pipe to avoid kinks. **(Fig. 24)**
  - m) Re-assemble the vehicle in the reverse order of disassembly. The large plastic cover behind the headlights that was retained by the three plastic rivets does not need to be reinstalled.
  - n) At this point the entire intake tube and filter can be re-adjusted for position and alignment. Make sure that no part of the **AEM** intake rubs anywhere along its length. **Critical points to check are on the corner of the plastic battery box and at the bend in the pipe just above the air filter.**
  - o) Connect the battery cables.
- 4) **Final inspection of installed components**
- a) Verify that no items are left loose in the engine compartment before you do the initial start up.

**Caution: If you anticipate traversing deep water, remove this system and replace it with the original equipment intake system.**

**For Technical Inquiries  
Please E-Mail us at  
tech@aempower.com**

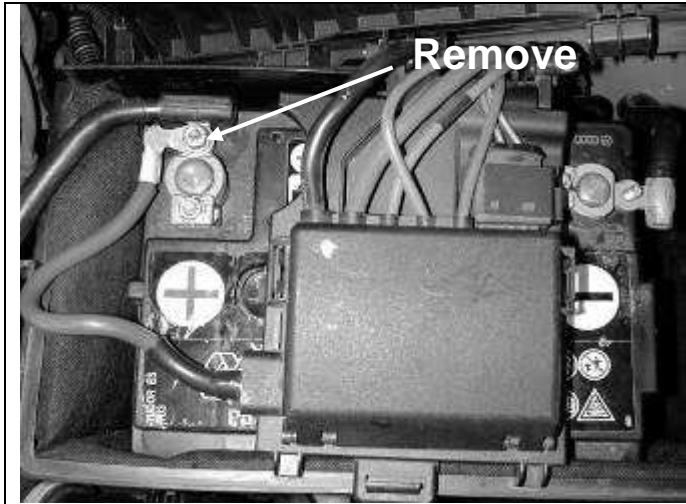

Fig. 1

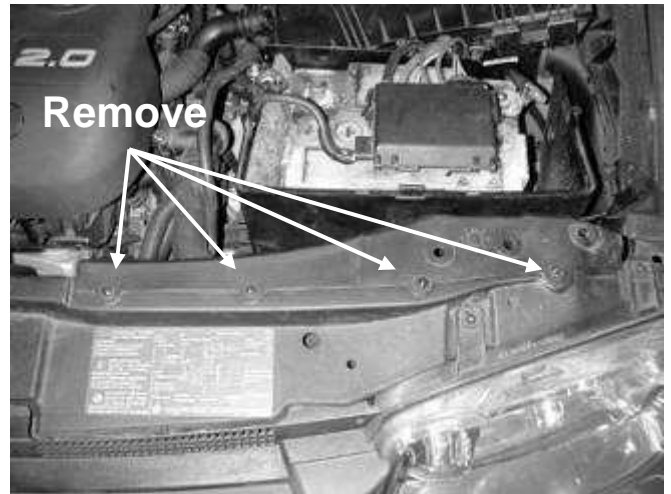

Fig. 2

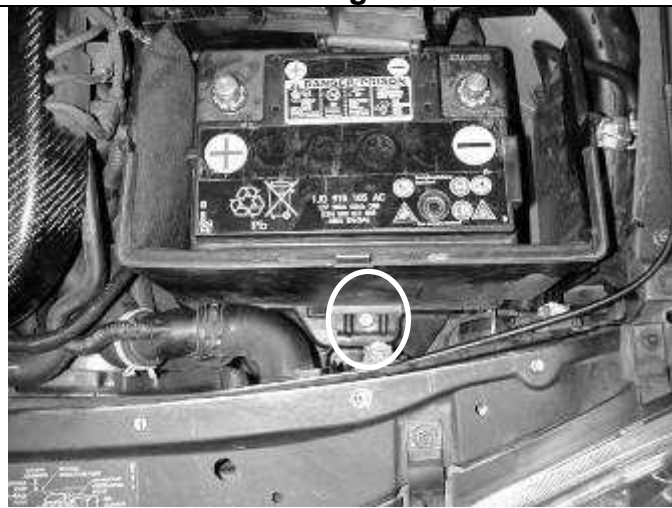

Fig. 3

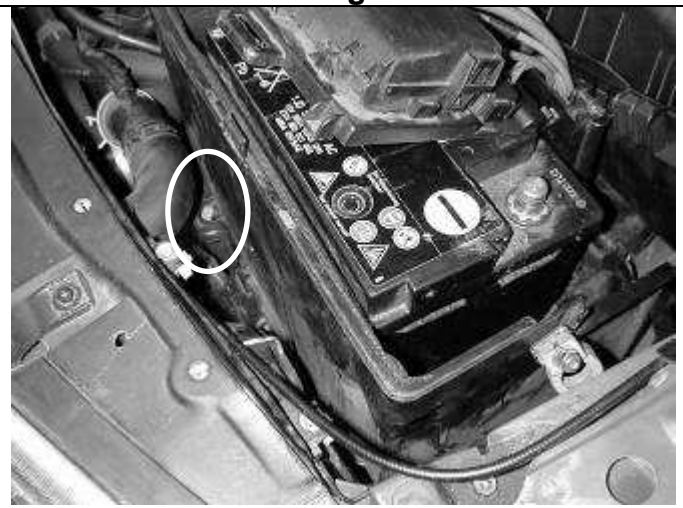

Fig. 4



Fig. 5

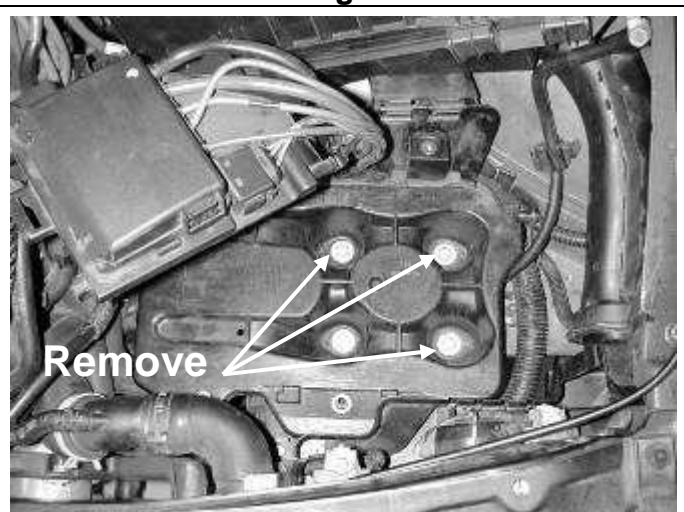

Fig. 6



**Fig. 7**



**Fig. 8**

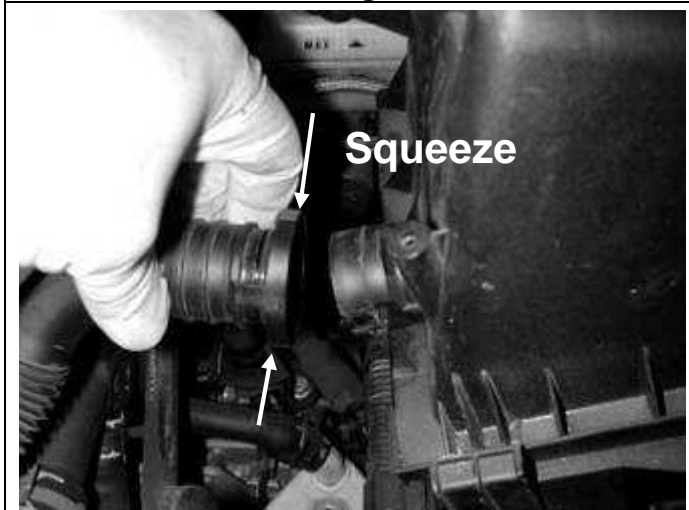

**Fig. 9**



**Fig. 10**



**Fig. 11**

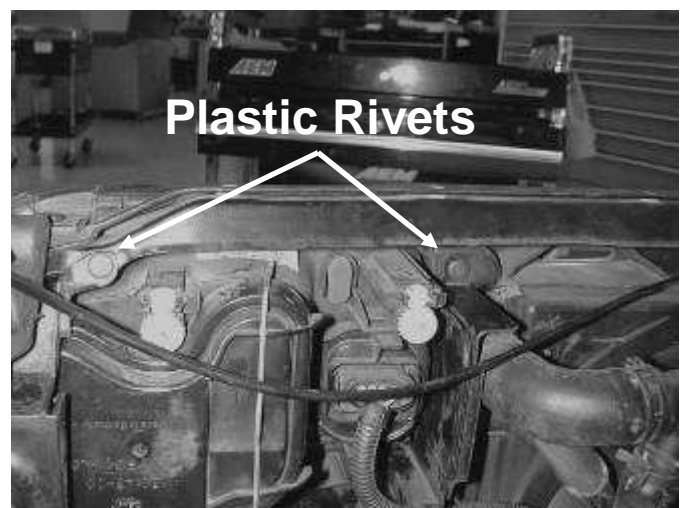

**Fig. 12**

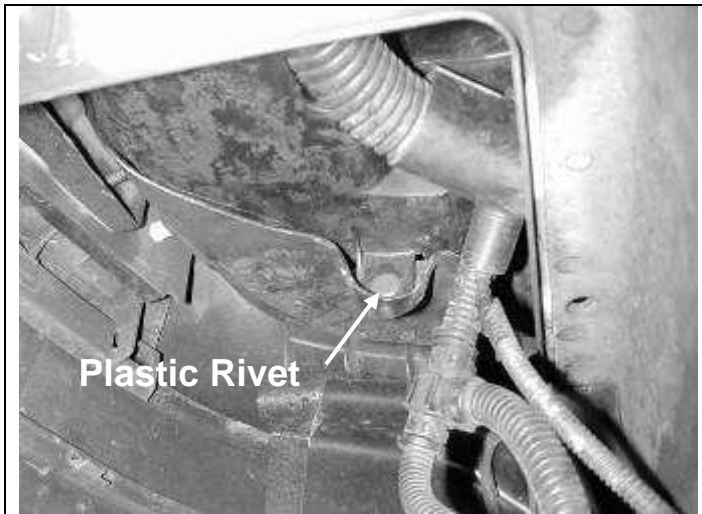

Plastic Rivet

Fig. 13



Fig. 14



Fig. 15

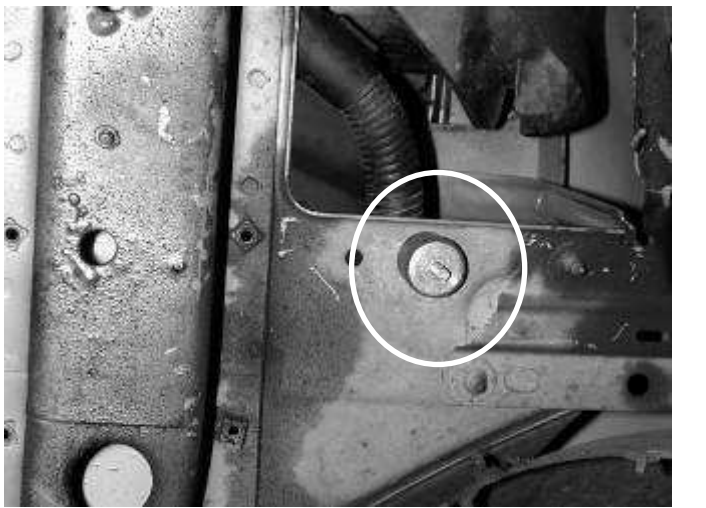

Fig. 16



Fig. 17



Fig. 18



**Fig. 19**



**Fig. 20**



**Fig. 21**



**Fig. 22**

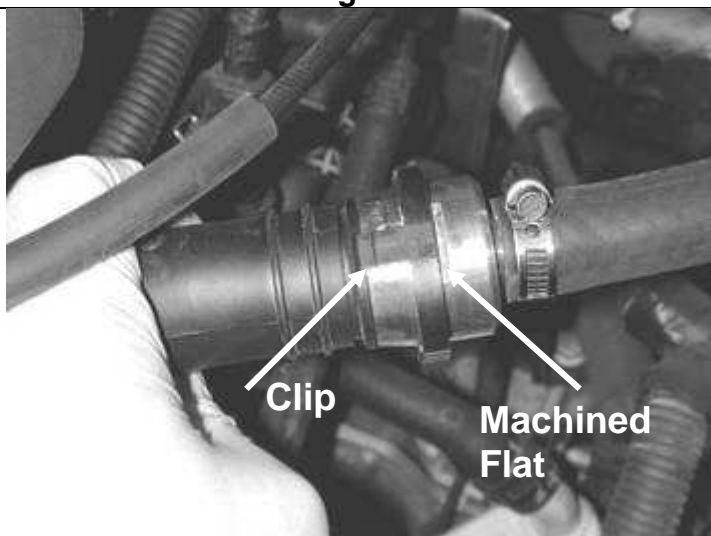

**Fig. 23**



**Fig. 24**



**Before**



**After**